

No. 658,540.

Patented Sept. 25, 1900.

F. W. BÜHNE & A. RITZ.
ROTARY NUT.

(Application filed June 12, 1900.)

(No Model.)

3 Sheets—Sheet 1.

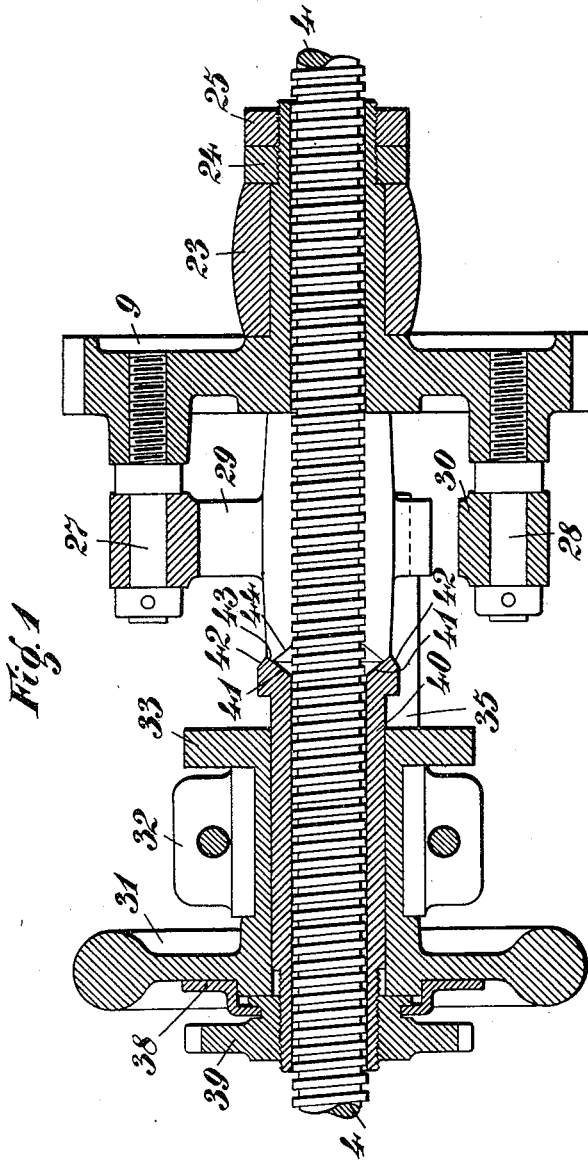

Fig. 1

WITNESSES:
Ella L. Giles
Oliver...

INVENTORS:
Friedrich Wilhelm Bühne
August Ritz
BY
Richard R.
ATTORNEYS

No. 658,540.

Patented Sept. 25, 1900.

F. W. BÜHNE & A. RITZ.
ROTARY NUT.

(Application filed June 12, 1900.)

(No Model.)

3 Sheets—Sheet 2.

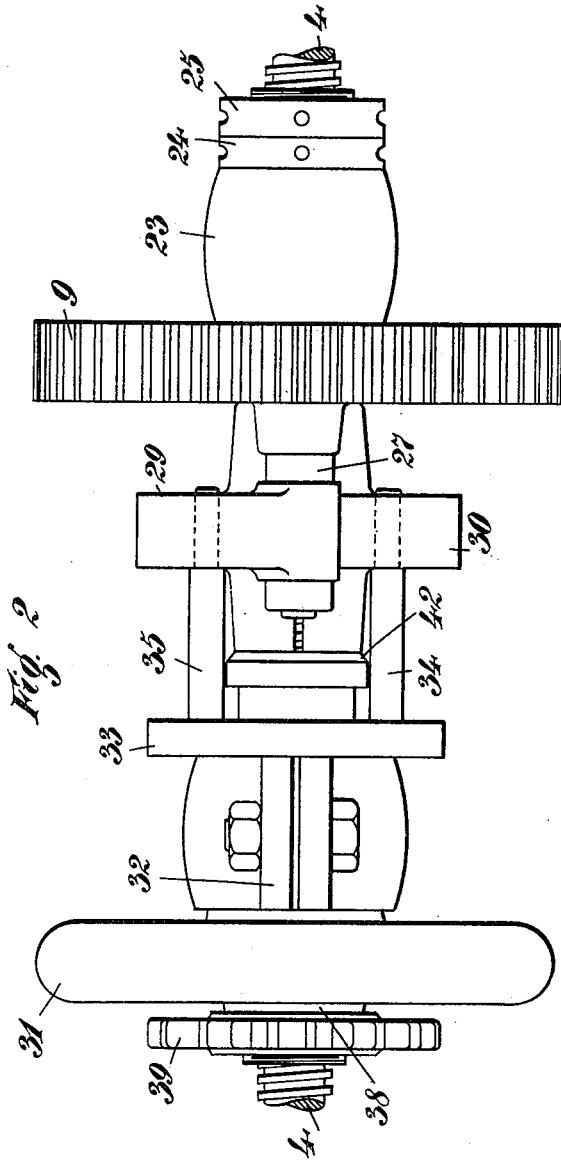

WITNESSES:
Elba L. Gilie
Oldmunk

INVENTORS.
Friedrich Wilhelm Bühne
August Ritz.
BY
Richard R.
ATTORNEYS

No. 658,540.

Patented Sept. 25, 1900.

F. W. BÜHNE & A. RITZ.
ROTARY NUT.

(Application filed June 12, 1900.)

(No Model.)

3 Sheets—Sheet 3.

Fig. 3

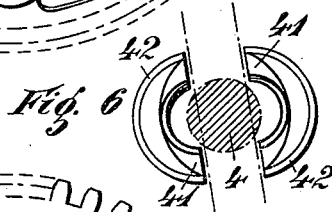
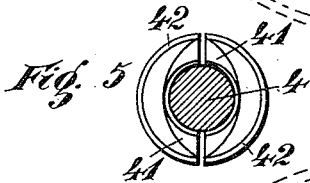
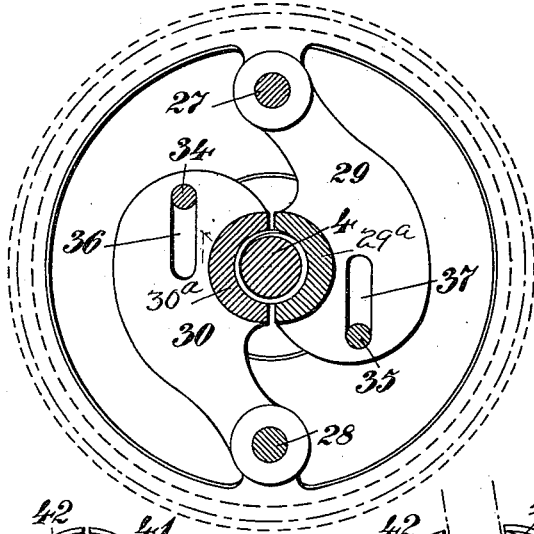
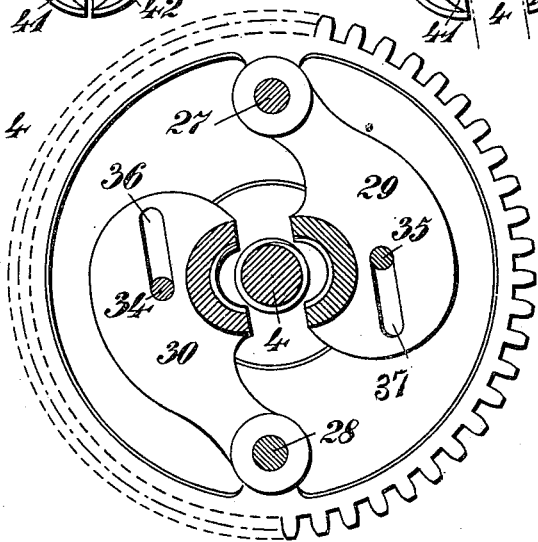

Fig. 4



WITNESSES:
Ella L. Giles
O. W. ...

INVENTORS:
Friedrich Wilhelm Bühne
August Ritz
BY
Richard A. ...

ATTORNEYS

UNITED STATES PATENT OFFICE.

FRIEDRICH WILHELM BÜHNE, OF FREIBURG, AND AUGUST RITZ, OF ST. GEORGEN, GERMANY.

ROTARY NUT.

SPECIFICATION forming part of Letters Patent No. 658,540, dated September 25, 1900.

Application filed June 12, 1900. Serial No. 20,015. (No model.)

To all whom it may concern:

Be it known that we, FRIEDRICH WILHELM BÜHNE, a resident of Freiburg, and AUGUST RITZ, a resident of St. Georgen, in the German Empire, subjects of the German Emperor have invented certain new and useful Improvements in Rotary Nuts, of which the following is a specification.

My invention relates to an improved rotary nut for use in connection with the feed screws or spindles of lathes and similar machines.

The invention is applicable to that class of machines in which a variety of speeds may be imparted to the carriage by not only imparting to the feed-screw rotary movement at varying rates of speed while the nut is held stationary, but also by imparting to the nut itself a rotary movement.

The object of the invention is to provide a nut which may be easily and quickly engaged with or disengaged from the feed-screw and may be firmly held against accidental displacement when in either its engaged or disengaged position.

The invention is illustrated in the accompanying drawings, in which—

Figure 1 is a longitudinal section through the rotary nut and its appurtenances. Fig. 2 is a plan of these parts. Fig. 3 is a cross-section through the front part of the nut, the latter being closed. Fig. 4 is a cross-section through the front part of the nut, the latter being opened. Fig. 5 is a side view of the closed mouth of the nut, together with the exterior cone which serves to secure the nut in position. Fig. 6 is a side view of the opened mouth of the nut, together with the interior cone serving for securing the nut in this position.

In the figures the numeral 4 indicates the feed-screw, to which motion is imparted by any suitable mechanism. (Not shown.)

The gear-wheel, by which movement is imparted to the nut, is shown at 9, journaled loosely on the screw and is provided with a tubular extension journaled in the bearing 23 of the tool rest or carriage or analogous part and held against longitudinal movement by the nuts 24 25. At one side of the wheel

9 are oppositely pivoted the arms 29 30, having threaded portions 29^a 30^a, forming a two-part nut for engaging the feed-screw.

For opening and closing the nut use is made of a hand-wheel 31, which may be rotated in the two-part bearing 32 and the end of which is provided with a disk 33. The latter carries two bolts 34 35, (see also Figs. 1 and 2,) the ends of which fit into slots 36 37 of the arms 29 30. (See Figs. 1, 3, and 4.) The hand-wheel 31 has radially-located projections 38, which enter a groove in the nut 39 and prevent a longitudinal displacement of this nut. A sleeve 14, encircling the screw and rotating in the tubular hub extension of the hand-wheel 31, is provided at one end with a screw-thread, upon which fits the nut 39. At the other end of the sleeve is a double cone consisting of the interior cone 41 and the exterior cone 42. These interior and exterior cone-surfaces are adapted to engage corresponding cones 43 and 44 on the two-part nut, according to whether the nut is opened or closed.

The two bearings 32 and 23, between which the whole arrangement is located, are carried by a part of the ordinary tool rest or carriage, which it is not deemed necessary to illustrate herein.

The manner of action of this arrangement is as follows: When the nut is to be opened, so that the whole device may be freely shoved over the thread of the feed-screw, the nut 39 is turned to the right, whereby the sleeve 14 moves away from the nut, and the interior cone 41, which is shown in Fig. 1 in engagement with the exterior cone 43 of the two halves 29^a and 30^a of the nut, is disengaged therefrom. As soon as this disengagement is effected a small rotation of the hand-wheel 31 rotates the disk 33 and the bolts 34 35, attached thereto, and these, traveling in the cam-slots 36 37, lift the two arms 29 30 and remove the threaded portions off the feed-screw, as represented in Fig. 4. To prevent the nut from arbitrarily closing, the nut 39 is turned to the left, so as to cause it to press the exterior cone 42 onto the interior cone 44 of the nut-sections, so that the nut cannot

close accidentally, and the whole system may freely be shoved along over the feed-screw. If the nut is to be closed, so as to be operated by the action of the screw, then first the double cone is withdrawn by turning the nut 39 to the right, whereupon the connection between the exterior cone 42 and interior cone 44 of the nut 29 30 is broken. A small rotation of the hand-wheel 31 is then sufficient to cause the bolts 34 35 to close the nut by acting upon the slots 36 37 when the nut has assumed the position shown in Fig. 3. In order to now prevent the nut from accidentally opening, the nut 39 is turned to the left, so as to cause the interior cone 41 to press upon the exterior cone 43 of the two-part nut.

Having now described my invention, what I claim is—

1. In a lathe or the like, the combination with the feed-screw, of a wheel loosely mounted on said screw, arms pivoted to said wheel having threaded portions for engaging said screw; a rotary hand-wheel, and projections operatively connected with said hand-wheel and engaging cam-surfaces on said nuts, substantially as described.

2. In a lathe or the like, the combination with the feed-screw, of a wheel loosely mounted thereon and connected with the tool-rest, arms pivotally connected with said wheel, and having threaded portions for engaging the screw, means for swinging said arms into or out of engagement with said screw, and means for locking said arms in either their engaged

or disengaged position, substantially as described.

3. In combination, the feed-screw, the two-part nut including separable nut-sections having each opposite inclines on its outer edge, means for operating said sections to engage them with and disengage them from the screw, and a longitudinally-movable sleeve on said screw having opposite inclines for engaging the corresponding inclines on the nut, substantially as described.

4. In a lathe, the combination with the feed-screw of a wheel encircling said screw and journaled in the tool-rest, arms pivoted to said wheel having nut portions for engaging and disengaging said screw, a longitudinally-movable sleeve encircling said screw, means carried by said sleeve for engaging said nut portions for holding them either in an engaged or disengaged position, means for operating said sleeve, a second sleeve encircling said first-named sleeve and turning in a bearing carried by the tool-rest, projections carried by said second sleeve and engaging cam-slots in the arms, and a hand-wheel for operating said second sleeve, substantially as described.

In witness whereof we have hereunto set our hands in presence of two witnesses.

FRIEDRICH WILHELM BÜHNE.
AUGUST RITZ.

Witnesses:

LUDWIG DREIER,
BENJ. F. LIEFELD.